



TRANSFORMER BOBBIN
INDUSTRIAL CO.,LTD.

Tel : 86-769-88789999 Fax : 86-769-88789989
http:// tbi-tw.com e-mail : tb6688@ms46.hinet.net

REVISIONS

REV	SYM	DRAFTER	CHECKER	DATE
9		T.S.LII	W.H.HSU	09/30/04
10		T.S.LII	W.H.HSU	07/22/06
11		Y.G.HSU	W.H.HSU	02/03/07

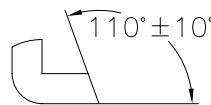
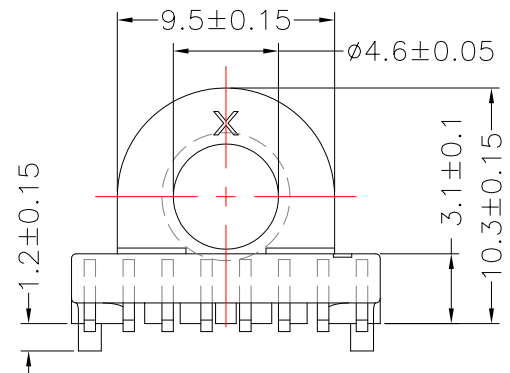
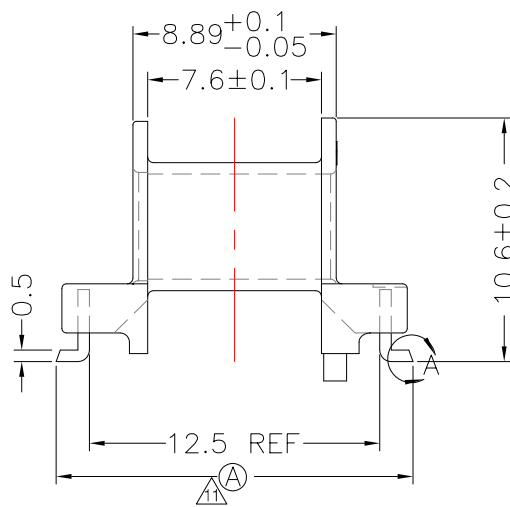
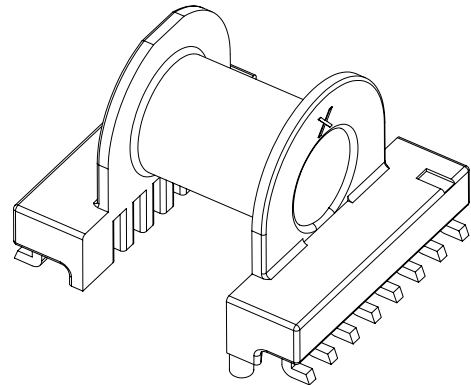
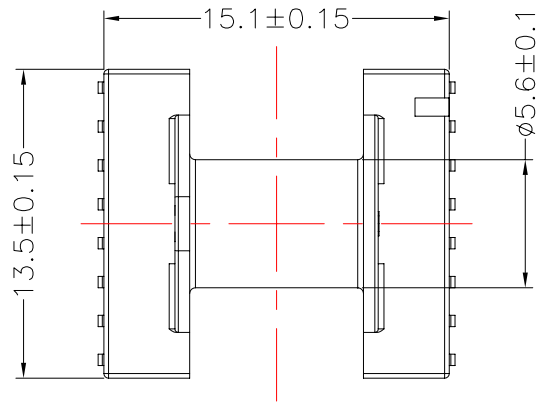

DETAIL:A
PATENTED

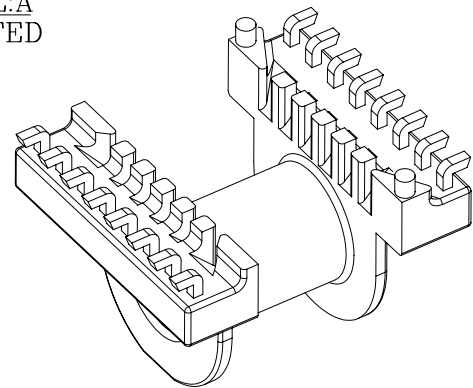
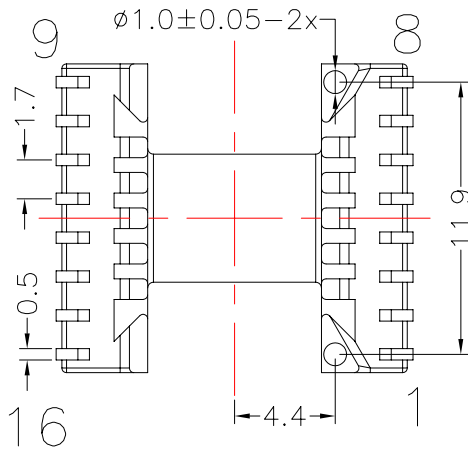

DWG NO. EP13-16P-L-1.7-A4-1

PART NO.	MATERIAL (BOBBIN)	MATERIAL (TERMINAL)	TERMINAL (PLATING)	PIN ALLOCATION	NOTE
TBI-103-03141.103	PM-9630	P.B	Sn	ALL PIN (A)= 15.6±0.2	
TBI-103-03141.113	PM-9630	P.B	Sn	PIN CUT #10,12,13,15 (A)= 15.6±0.2	
TBI-103-03141.123	PM-9630	P.B	Sn	PIN CUT #10,12,13,15 (A)= 17±0.2	

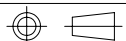

TOLERANCE: .X±0.15 .XX±0.10 .XXX±0.05

UNIT : m / m

SCALE 3 : 1

Finish: 1. Pb wire Immersion Sn on terminal : Thickness:Sn plating,100,5 μm (200 μ inches) min,Base nickel 0.625 μm (25 μ inches) min.
2. CP wire Immersion Sn on terminal : Thickness:Sn plating,100,5 μm (200 μ inches) min.
3. Coplanarity deviation: 0.10 mm (0.004 inches) max.

REV 11