

A-CORE

A-CORE JIANGMEN ELECTRONICS CO.,LTD
 江門安磁電子有限公司

TBI

TRANSFORMER BOBBIN
 INDUSTRIAL CO.,LTD.

ELECTRICAL CO. Tel : 86-750-3867791 Fax : 86-750-3867787

Tel : 86-769-88789999 Fax : 86-769-88789989

e-mail : sales@acore-ferrite.com

http:// tbi-tw.com e-mail : tb6688@ms46.hinet.net

REVISIONS

REV	SYM	DRAFTER	CHECKER	DATE
△1		X.H.GU	G.F.YANG	01/06/15
△2				
△3				

TOP

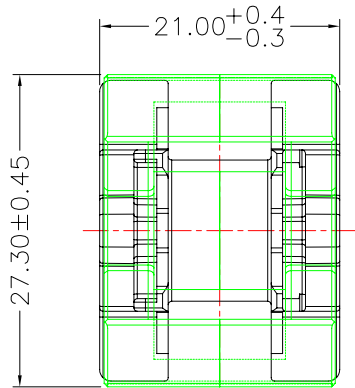

TOP

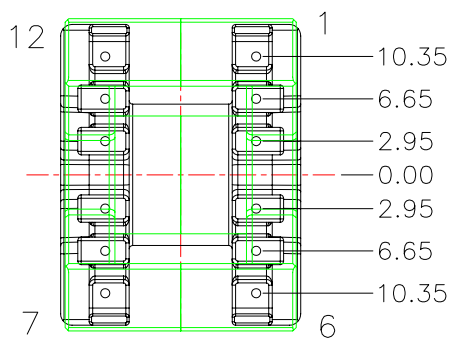
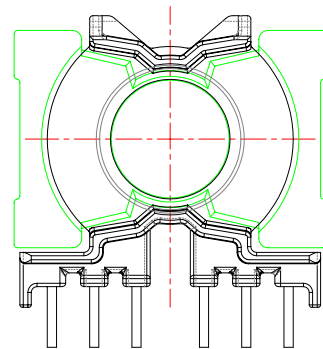
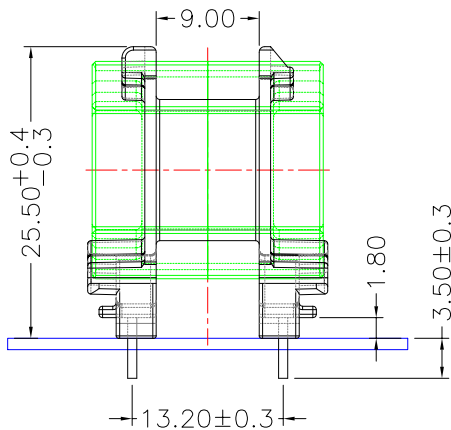
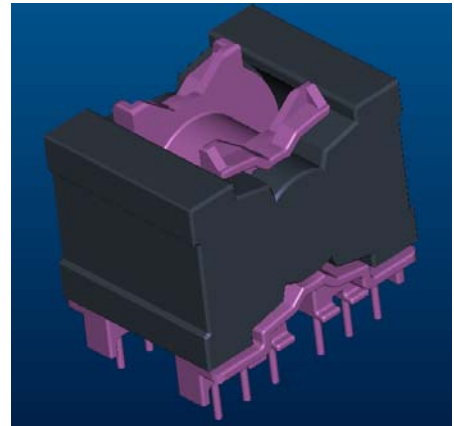

BOTTOM

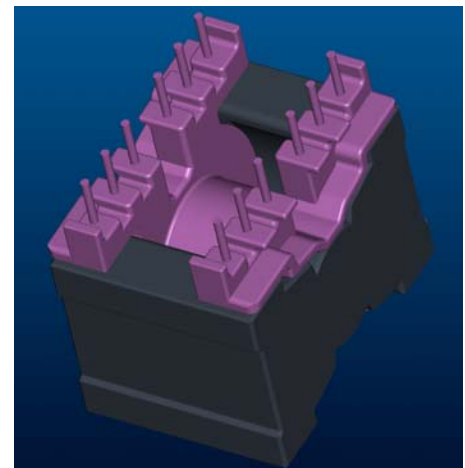

BOTTOM

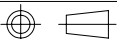
ITEM	PART NO.	MATERIAL	DWG NO.	Core Set Parameters
CORE	PQ26/20	JPP-44A		C1=?mm ⁻¹ Le=?mm Ae=?mm ² Ve=?mm ³
CORE	PQ26/20	JPP-95		
BOBBIN	TBI-216-04141.11XX		PQ2620-12P-TH-A4-11	
 UNIT : m / m				SCALE 1 : 1

REV 1