





**A-CORE**

A-CORE JIANGMEN ELECTRONICS CO.,LTD  
江門安磁電子有限公司

**TBI**

TRANSFORMER BOBBIN  
INDUSTRIAL CO.,LTD.

ELECTRICAL CO. Tel : 86-750-3867791 Fax : 86-750-3867787

Tel : 86-769-88789999 Fax : 86-769-88789989

e-mail : sales@acore-ferrite.com

http:// tbi-tw.com e-mail : tb6688@ms46.hinet.net

REVISIONS

REV	SYM	DRAFTER	CHECKER	DATE
3		X.H.GU	G.F.YANG	10/24/17
4		X.H.GU	G.F.YANG	09/06/19
5				

TOP

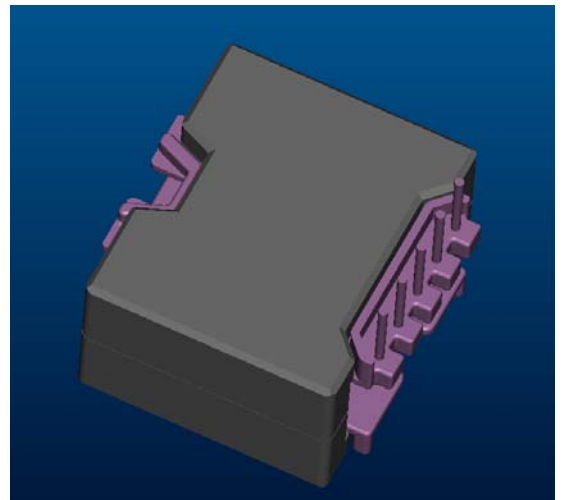
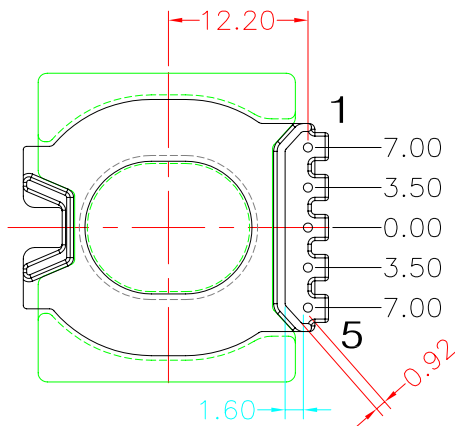
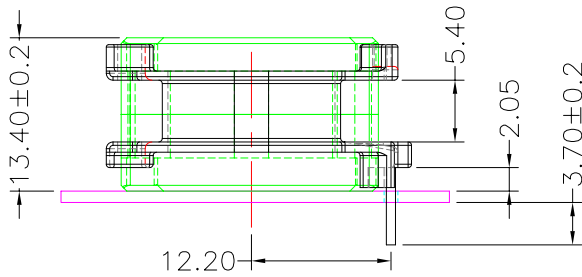
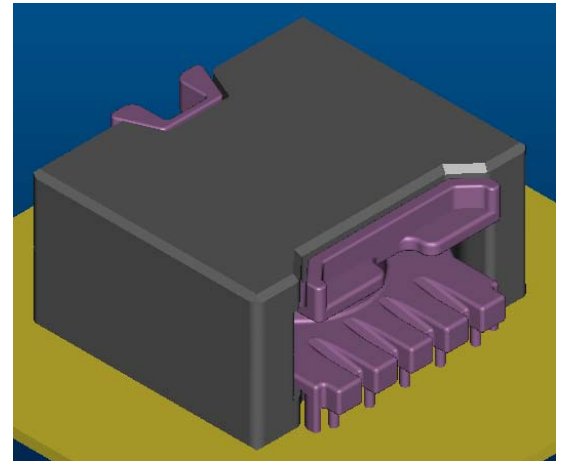
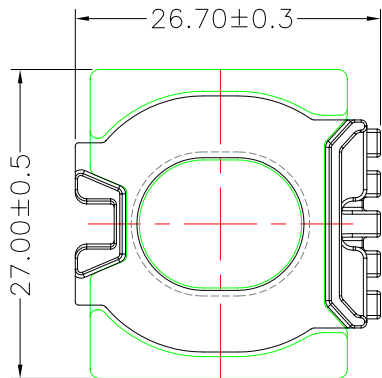

BOTTOM

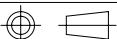
ITEM	PART NO.	MATERIAL	DWG NO.	Core Set Parameters
CORE	ATQ27-13.4	JPP-44A		Ae=131.6mm <sup>2</sup> Le=41mm C1=0.312mm <sup>-1</sup> Ve=5395.6mm <sup>3</sup>
CORE	ATQ27-13.4	JPP-95		
BOBBIN	TBI-238-03531.17XX		ATQ27-13.4-5P-TH-E3-17	
				SCALE 1 : 1

UNIT : m/m

REV 2