



TRANSFORMER BOBBIN INDUSTRIAL CO.,LTD.

Tel : 86-769-88789999 Fax : 86-769-88789989
http://tbi-tw.com e-mail : tb6688@ms46.hinet.net

REVISIONS				
REV	SYM	DRAFTER	CHECKER	DATE
△1		X.H.GU	G.F.YANG	06/02/12
△2		F.LU	G.F.YANG	01/31/13
△3				

A

A

B

B

C

C

D

D

E

E

F

F

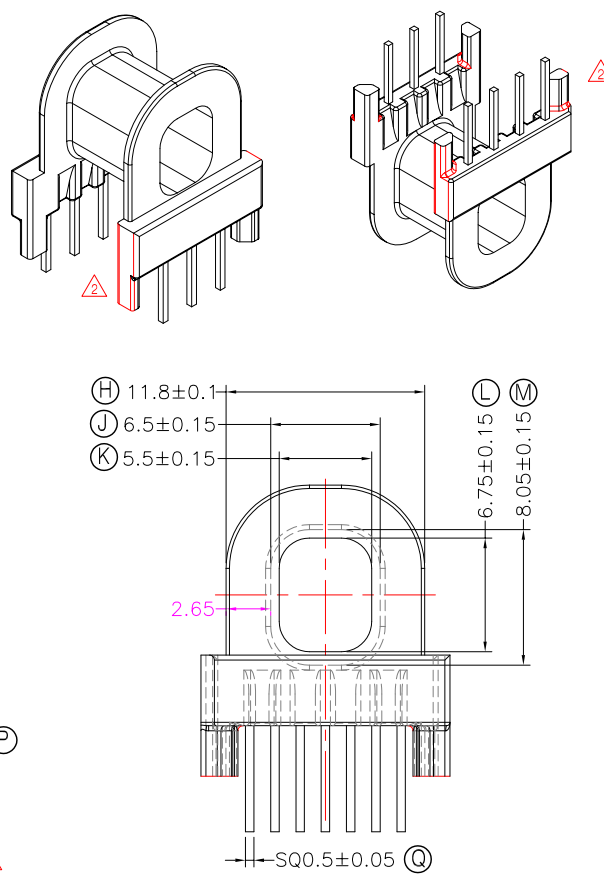
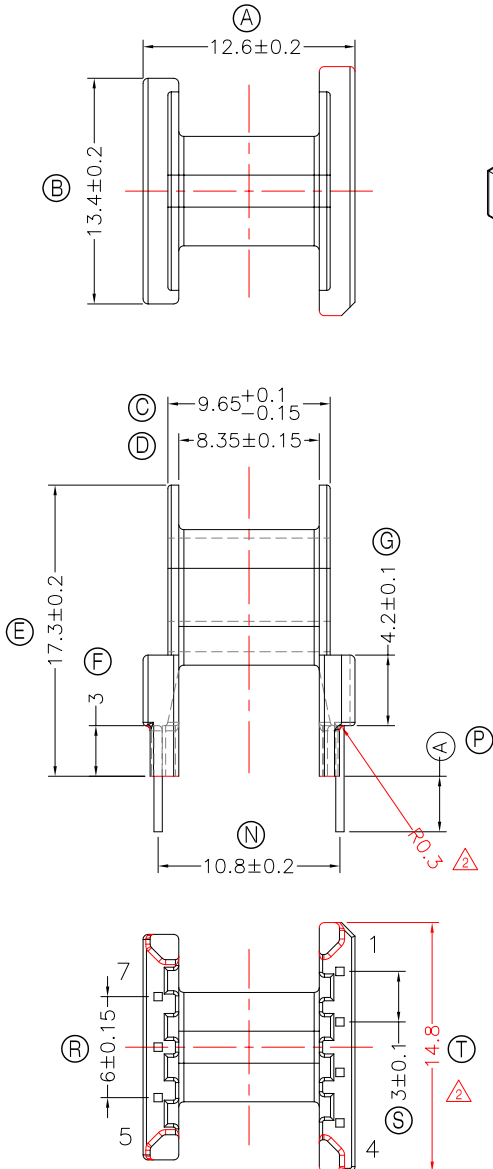

- NOTE:
1. 焊錫前拉力:1.0KG MIN, 焊錫後拉力:1.5KG MIN;
 2. 任意一點強度須1.5kg MIN;
 3. 耐壓4.0Kv /1.5mA 60S;
 4. 焊錫溫度:450°±10° 3SEC
 5. WINDING SPACE:8.35mm*2.65mm=22.13 mm²

DWG NO.	ATP15-13-7P-TH-F-11				
PART NO.	MATERIAL (BOBBIN)	MATERIAL (TERMINAL)	TERMINAL (PLATING)	PIN ALLOCATION	NOTE
TBI-238-27061.1106	PM-9630	CP WIRE	Sn	ALL PIN (A)=3.3±0.3	S
TBI-238-27061.1116	PM-9630	CP WIRE	Sn	NO PIN#1,2,5,6,7 (A)=3.3±0.3	H
TBI-238-27061.1126	PM-9630	CP WIRE	Sn	NO PIN#2,3,5,6 (A)=3.5±0.3	
TBI-238-27061.1136	PM-9630	CP WIRE	Sn	NO PIN#1,3,5,6,7 (A)=3.3±0.3	
TBI-238-27061.1146	PM-9630	CP WIRE	Sn	NO PIN#1,2,7 (A)=3.3±0.3	
TBI-238-27061.1156	PM-9630	CP WIRE	Sn	NO PIN#1,3,5,6,7 (A)=5.0±0.5	暫無刀模
TBI-238-27061.1166	PM-9630	CP WIRE	Sn	NO PIN#1,2,5,7 (A)=3.3±0.3	
TBI-238-27061.1176	PM-9630	CP WIRE	Sn	NO PIN#1,2,6,7 (A)=3.3±0.3	
TBI-238-27061.1186	PM-9630	CP WIRE	Sn	NO PIN#1,2,3,5 (A)=3.3±0.3	
TBI-238-27061.1196	PM-9630	CP WIRE	Sn	NO PIN#1,3,6,7 (A)=3.3±0.3	
TBI-238-27061.11A6	PM-9630	CP WIRE	Sn	NO PIN#1,3,6,7 (A)=5.0±0.5	暫無刀模
TBI-238-27061.11B6	PM-9630	CP WIRE	Sn	NO PIN#1,2,3,5 (A)=5.0±0.5	暫無刀模
TBI-238-27061.11C6	PM-9630	CP WIRE	Sn	NO PIN#2 (A)=3.5±0.3	
TBI-238-27061.11D6	PM-9630	CP WIRE	Sn	NO PIN#3,4,5,7 (A)=3.3±0.3	
TBI-238-27061.11E6	PM-9630	CP WIRE	Sn	NO PIN#1,4,5,6,7 (A)=3.3±0.3	
TBI-238-27061.11F6	PM-9630	CP WIRE	Sn	NO PIN#5,6,7 (A)=3.3±0.3	
TBI-238-27061.11G6	PM-9630	CP WIRE	Sn	NO PIN#6,7 (A)=3.4±0.2	

TOLERANCE: 0<L<=4:±0.1 4<L<=16:±0.2 16<L<=63:±0.3 UNIT : m/m SCALE 1 : 1

Finish: 1. PB wire Immersion Sn on terminal : Thickness:Sn plating,100.5 μm (200 μ inches) min,Base nickel 0.625 μm (25 μ inches) min.
2. CP wire Immersion Sn on terminal : Thickness:Sn plating,100.5 μm (200 μ inches) min.
3. Coplanarity deviation: 0.10 mm (0.004 inches)max.

REV 2

A-CORE

A-CORE JIANGMEN ELECTRONICS CO.,LTD
 江門安磁電子有限公司

TBI

TRANSFORMER BOBBIN
 INDUSTRIAL CO.,LTD.

ELECTRICAL CO. Tel : 86-750-3867791 Fax : 86-750-3867787

Tel : 86-769-88789999 Fax : 86-769-88789989

e-mail : sales@acore-ferrite.com

http:// tbi-tw.com e-mail : tb6688@ms46.hinet.net

REVISIONS

REV	SYM	DRAFTER	CHECKER	DATE
△1		X.H.GU	G.F.YANG	06/02/12
△2		F.LU	G.F.YANG	01/31/13
△3				

TOP

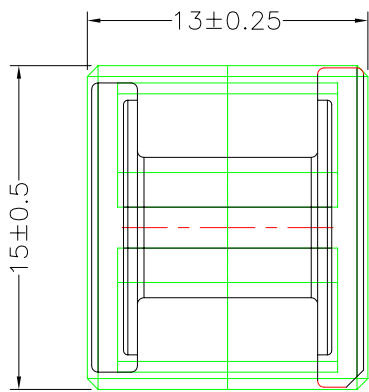

TOP

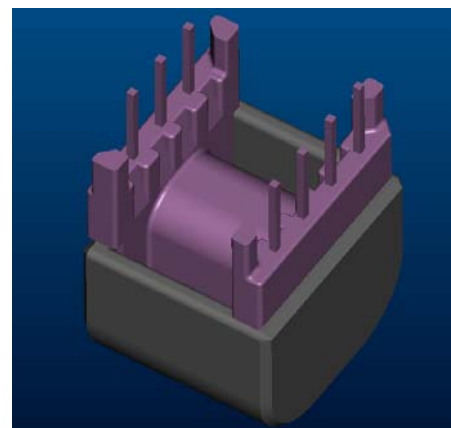
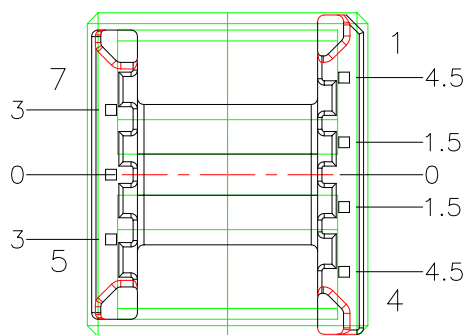
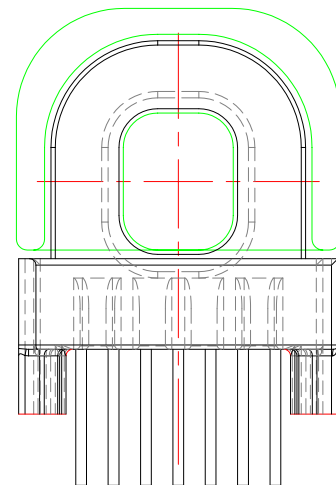
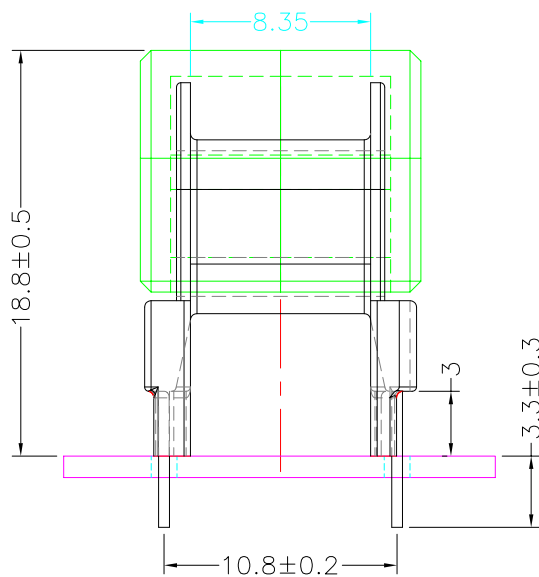
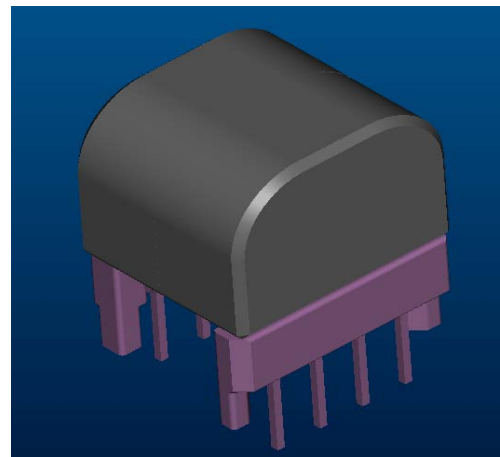

BOTTOM

BOTTOM

ITEM	PART NO.	MATERIAL	DWG NO.	Core Set Parameters
CORE	ATP15/13	JPP-44A		Ae=33.3mm ² Le=38.7mm C1=1.16mm ⁻¹ Ve=1288.71mm ³
CORE	ATP15/13	JPP-95		
BOBBIN	TBI-238-27061.11XX		ATP15-13-7P-TH-F-11	

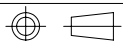

UNIT : m/m

SCALE 1 : 1

REV 2