

A-CORE
ELECTRICAL CO.

A-CORE JIANGMEN ELECTRONICS CO.,LTD
 江门安磁电子有限公司
 Tel: 86-750-3867791 Fax : 86-750-3867787

| REVISIONS | | | | |
|-----------|-----|---------|----------|----------|
| REV | SYM | DRAFTER | CHECKER | DATE |
| 1 | | X.H.GU | G.F.YANG | 01/25/13 |
| 2 | | | | |
| 3 | | | | |

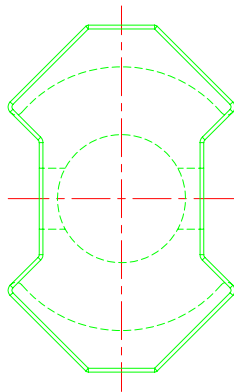
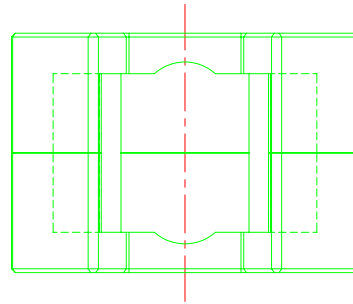
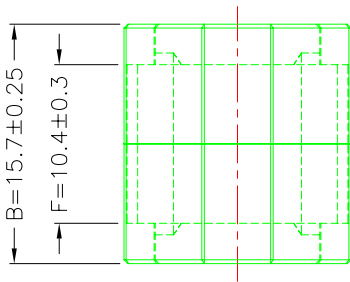
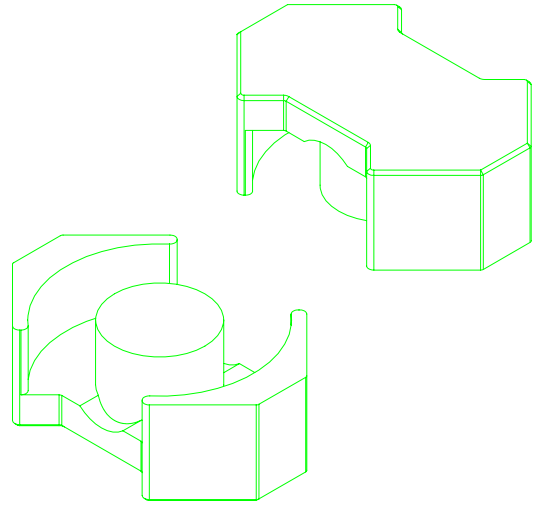
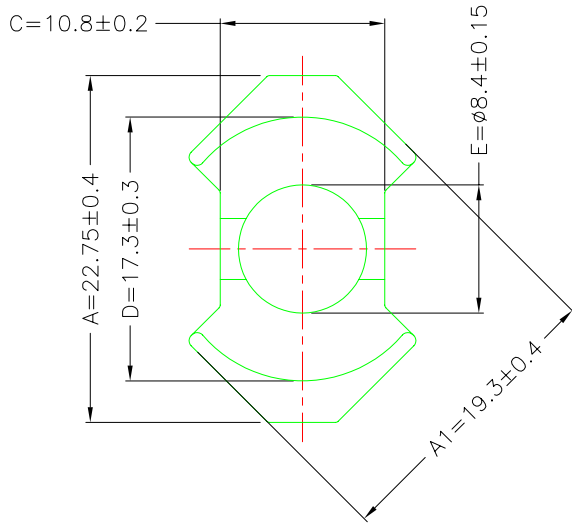

Core Set Parameters

$A_e=62.3\text{mm}^2$
 $L_e=37.1\text{mm}$
 $C_1=0.596\text{mm}^{-1}$
 $V_e=2311.33\text{mm}^3$

| | | | | | |
|-----------|-------------------|---------------------|--------------------|----------------|------|
| DWG NO. | RM8/15.7G- CORE | | | | |
| PART NO. | MATERIAL (BOBBIN) | MATERIAL (TERMINAL) | TERMINAL (PLATING) | PIN ALLOCATION | NOTE |
| RM8/15.7G | JPP-44A | | | | |
| RM8/15.7G | JPP-95 | | | | |
| | | | | | |
| | | | | | |
| | | | | | |

| | | | |
|---------|---|--------------|-------------|
| Finish: | TOLERANCE: 0<L<=4:±0.1 4<L<=16:±0.2 16<L<=63:±0.3 | UNIT : m / m | SCALE 1 : 1 |
| | | | REV 1 |

A-COREA-CORE JIANGMEN ELECTRONICS CO.,LTD
江门安磁电子有限公司**TBI**TRANSFORMER BOBBIN
INDUSTRIAL CO.,LTD.

ELECTRICAL CO. Tel : 86-750-3867791 Fax : 86-750-3867787

Tel : 86-769-88789999 Fax : 86-769-88789989

e-mail : sales@acore-ferrite.com

http:// tbi-tw.com e-mail : tb6688@ms46.hinet.net

REVISIONS

| REV | SYM | DRAFTER | CHECKER | DATE |
|-----|-----|---------|----------|----------|
| △1 | | X.H.GU | G.F.YANG | 06/10/15 |
| △2 | | | | |
| △3 | | | | |

TOP

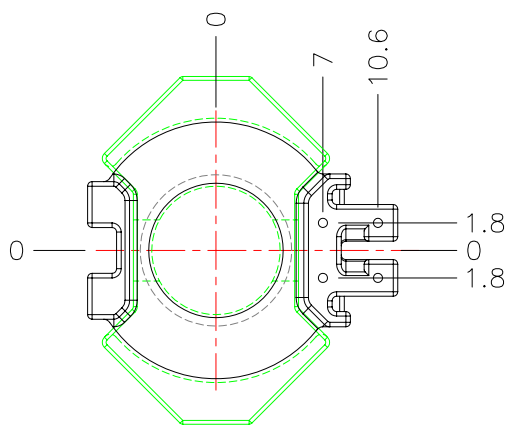
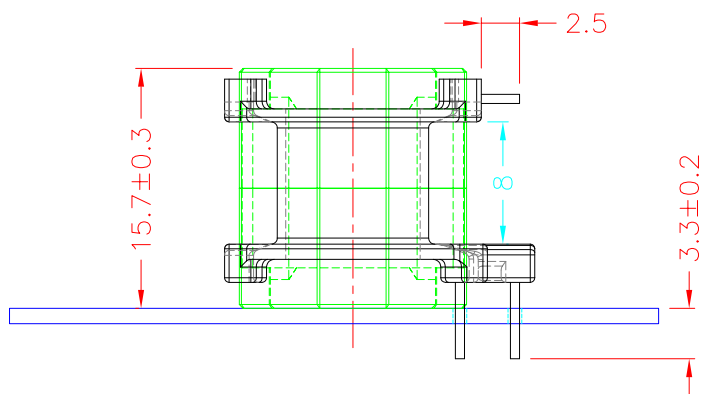
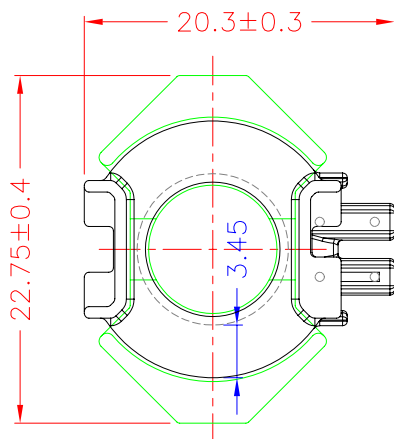

BOTTOM

| ITEM | PART NO. | MATERIAL | DWG NO. | Core Set Parameters |
|--------|--------------------|----------|-----------------------|---|
| CORE | RM8/15.7G | JPP-44A | | $A_e=62.3\text{mm}^2$ $L_e=37.1\text{mm}$ $C_1=0.596\text{mm}^{-1}$ $V_e=2311.33\text{mm}^3$ |
| CORE | RM8/15.7G | JPP-95 | | |
| BOBBIN | TBI-208-05291.11XX | | RM8-15.7G-5P-TH-B9-11 | |
| | | | | |

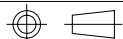

UNIT : m / m

SCALE 1 : 1

REV

1