



TRANSFORMER BOBBIN
INDUSTRIAL CO.,LTD.

Tel : 86-769-88789999 Fax : 86-769-88789989
http:// tbi-tw.com e-mail : tb6688@ms46.hinet.net

REVISIONS

REV	SYM	DRAFTER	CHECKER	DATE
△1		X.X.YUAN	G.F.YANG	05/10/11
△2		X.H.GU	G.F.YANG	10/18/13
△3		M.WANG	G.F.YANG	08/25/16

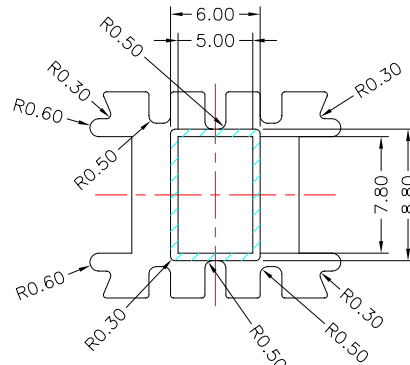
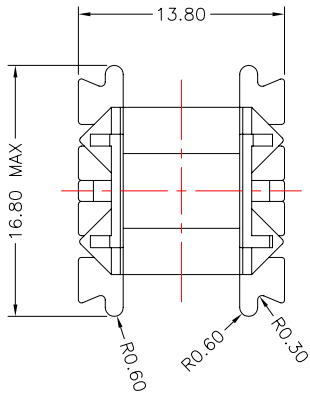

Section A-A

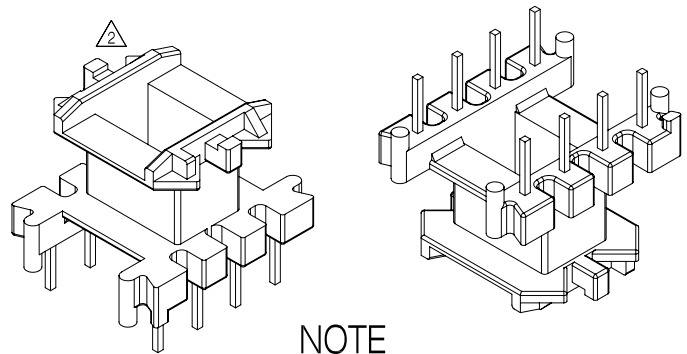
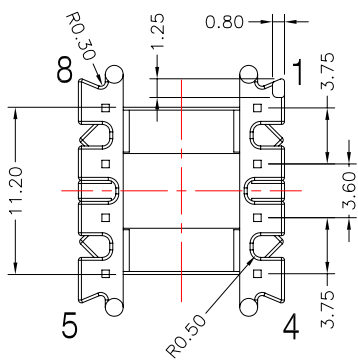
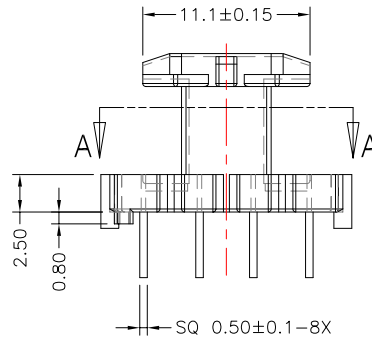
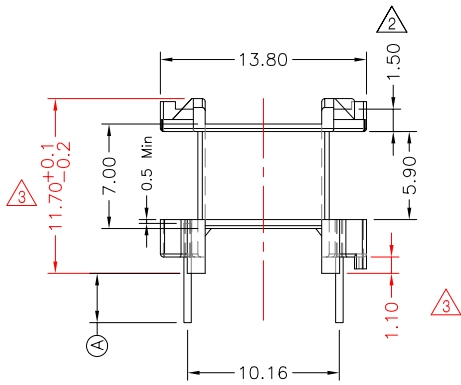

NOTE

- 1.拉力:1.0 Kg Min
- 2.未標示之圓角皆為R0.2mm;

DWG NO.	EF16-8P-TH-B2-11				
PART NO.	MATERIAL (BOBBIN)	MATERIAL (TERMINAL)	TERMINAL (PLATING)	PIN ALLOCATION	NOTE
TBI-205-02221.1106	PM-9630(BK)	CP WIRE	Sn	ALL PIN (A)=3.1±0.2	
TBI-205-02221.1116	PM-9630(BK)	CP WIRE	Sn	CUT PIN #5,6,7,8 (A)=3.1±0.2	52GEE16V8P01 H
TBI-205-02221.1126	PM-9630(BK)	CP WIRE	Sn	CUT PIN #7,8 (A)=3.5±0.3	
TBI-205-02221.1136	PM-9630(BK)	CP WIRE	Sn	CUT PIN #4,7,8 (A)=3.1±0.2	52GEE168P001
TBI-205-02221.1146	PM-9630(BK)	CP WIRE	Sn	CUT PIN #8 (A)=3.1±0.2	52GEE168P002
TBI-205-02221.1156	PM-9630(BK)	CP WIRE	Sn	ALL PIN (A)=3.5±0.2	
TBI-205-02221.1166	PM-9630(BK)	CP WIRE	Sn	CUT PIN #2,3,4,6,7,8 (A)=3.1±0.2	
	TOLERANCE: 0<L<=4 ±0.1 4<L<=16 ±0.2 16<L<=63 ±0.3 pin pitch:±0.2			UNIT : m / m	SCALE 2 : 1

Finish: 1. Pb wire Immersion Sn on terminal : Thickness:Sn plating,100,5 μm (200 μ inches) min,Base nickel 0.625 μm (25 μ inches) min.
2. CP wire Immersion Sn on terminal : Thickness:Sn plating,100,5 μm (200 μ inches) min.
3. Coplanarity deviation: 0.10 mm (0.004 inches)max.

REV 3