

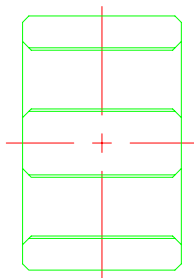

**A-CORE**  
ELECTRICAL CO.

A-CORE JIANGMEN ELECTRONICS CO.,LTD  
 江门安磁电子有限公司  
 Tel : 86-750-3867791 Fax : 86-750-3867787

REVISIONS				
REV	SYM	DRAFTER	CHECKER	DATE
①		YAN.TANG	G.F.YANG	05/04/09
②				
③				

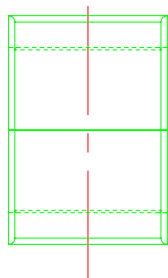
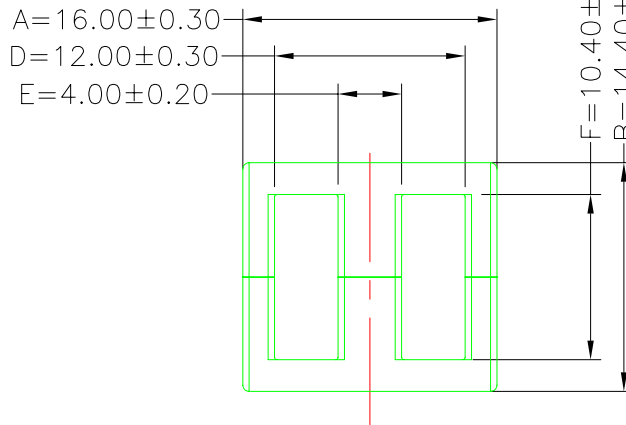
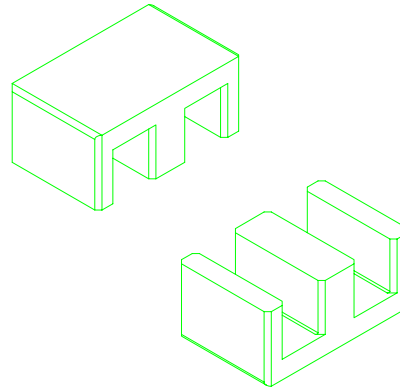
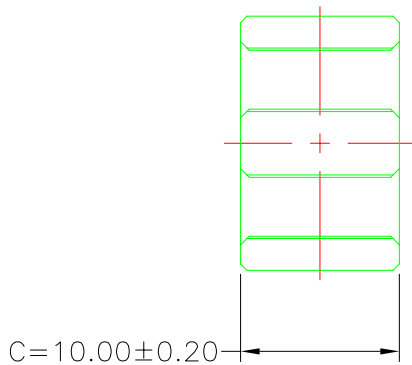

### Core Set Paramters

- A1(Limbs)=40mm<sup>2</sup>
- A2(back wall)=40mm<sup>2</sup>
- A3(center post)=40mm<sup>2</sup>
- Ae=40mm<sup>2</sup>
- Le=35.1mm
- C1=0.877mm<sup>-1</sup>

DWG NO.	EE16/14C-CORE			
PART NO.	MATERIAL (CORE)			NOTE
EE16/14C	JPP-44A			
EE16/14C	JPP-95			

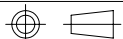

TOLERANCE: .XX±0.25 .XXX±0.127

UNIT : m/m

SCALE 1 : 1

REV 1

**A-CORE**

A-CORE JIANGMEN ELECTRONICS CO.,LTD  
 江門安磁電子有限公司

ELECTRICAL CO. Tel : 86-750-3867791 Fax : 86-750-3867787

e-mail : sales@acore-ferrite.com

**TBI**

TRANSFORMER BOBBIN  
 INDUSTRIAL CO.,LTD.

Tel : 86-769-88789999 Fax : 86-769-88789989

http:// tbi-tw.com e-mail : tb6688@ms46.hinet.net

REVISIONS

REV	SYM	DRAFTER	CHECKER	DATE
①		YAN.TANG	G.F.YANG	03/09/10
②		YAN.TANG	G.F.YANG	08/23/10
③				

TOP

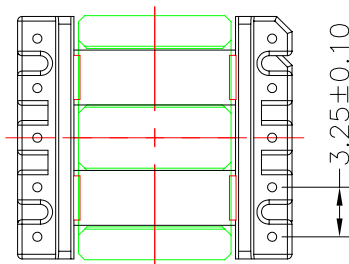
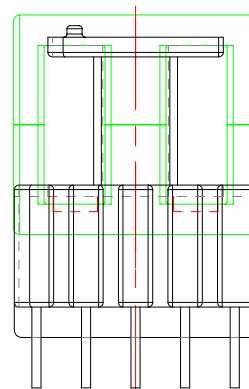
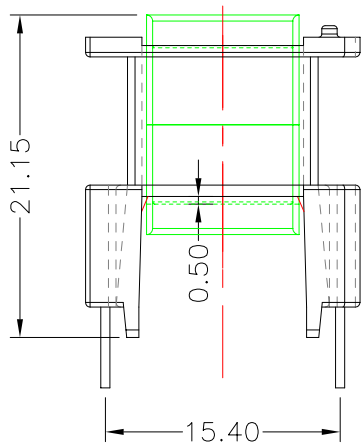
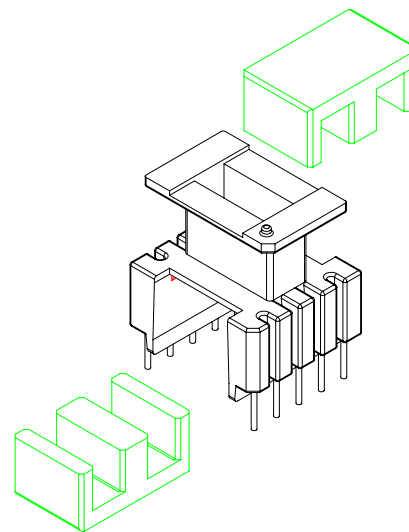
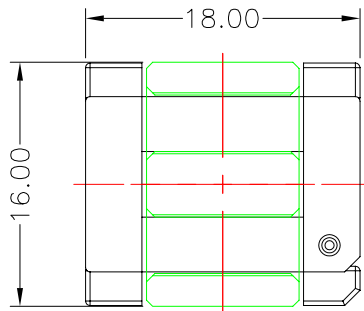

BOTTOM

ITEM	PART NO.	MATERIAL	DWG NO.	Core Set Parameters
CORE	EE16/14C	JPP-44A		$A_e=40\text{mm}^2$ $L_e=35.1\text{mm}$ $C_1=0.877\text{mm}^{-1}$ $V_e=1404\text{mm}^3$
CORE	EE16/14C	JPP-95		
BOBBIN	TBI-201-09031.11XX		EE16-14C-10P-TH-C-11	

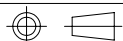

UNIT : m/m

SCALE 1 : 1

REV 2