





**TRANSFORMER BOBBIN  
INDUSTRIAL CO.,LTD.**

Tel : 86-769-88789999 Fax : 86-769-88789989  
 http:// tbi-tw.com e-mail : tb6688@ms46.hinet.net

REVISIONS

REV	SYM	DRAFTER	CHECKER	DATE
①		X.H.GU	G.F.YANG	06/03/10
②		YAN.TANG	G.F.YANG	06/04/10
③				

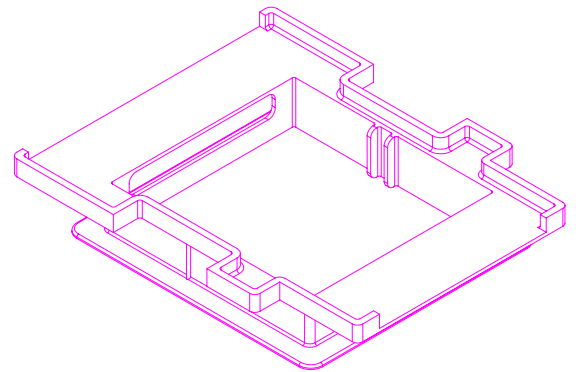
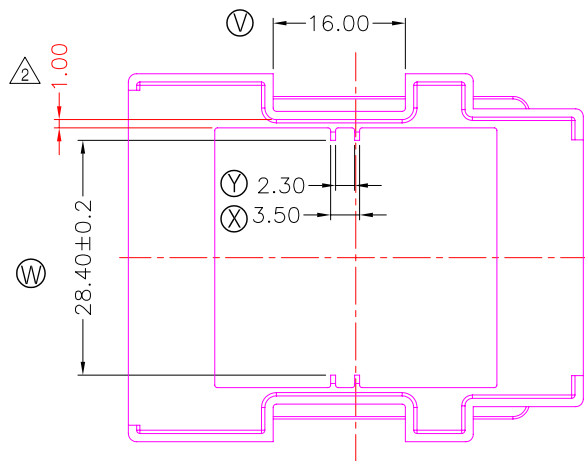
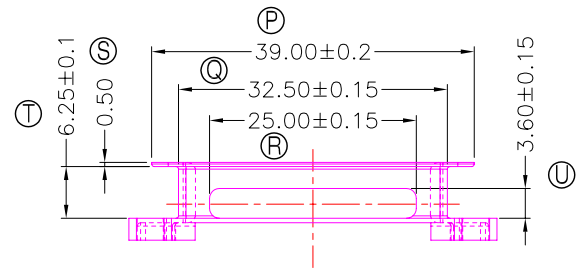
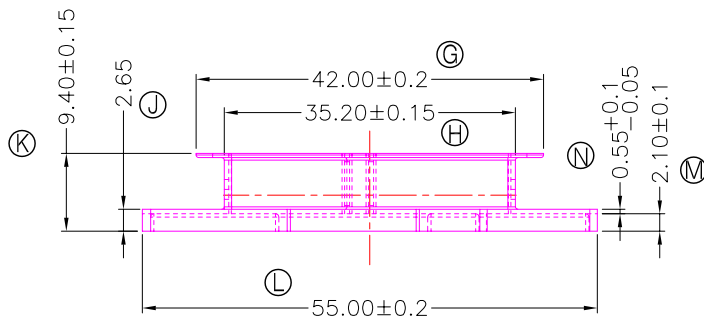
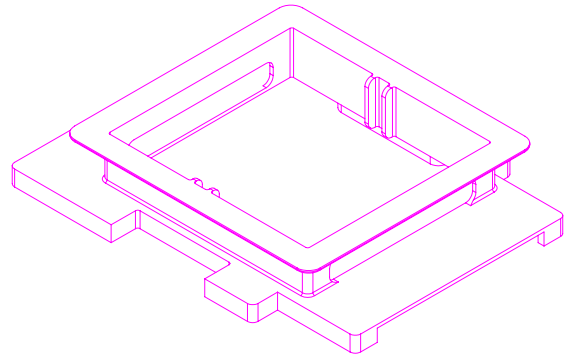
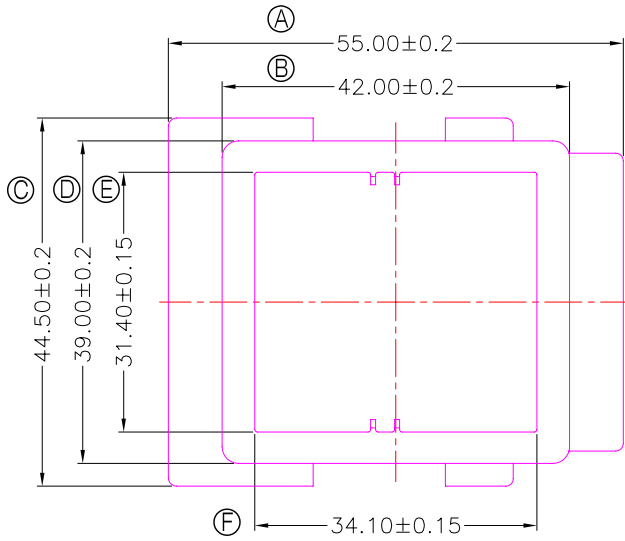

DWG NO. EFD45-49.4-CASE-B4-91

PART NO.	MATERIAL (BOBBIN)	MATERIAL (TERMINAL)	TERMINAL (PLATING)	PIN ALLOCATION	NOTE
TBI-207-08241.91C	PET FR530 (BK)	NA	NA	NA	S
					H



TOLERANCE: 0<L<=4: ±0.1 4<L<=16: ±0.2 16<L<=63: ±0.3

UNIT : m / m

SCALE 1 : 1

Finish: 1. PB wire Immersion Sn on terminal : Thickness:Sn plating,100,5 μm (200 μ inches) min,Base nickel 0.625 μm (25 μ inches) min.  
 2. CP wire Immersion Sn on terminal : Thickness:Sn plating,100,5 μm (200 μ inches) min.  
 3. Coplanarity deviation: 0.10 mm (0.004 inches) max.

REV 2

**A-CORE**  
ELECTRICAL CO.

A-CORE JIANGMEN ELECTRONICS CO.,LTD  
 江门安磁电子有限公司  
 Tel: 86-750-3867791 Fax : 86-750-3867787

REVISIONS				
REV	SYM	DRAFTER	CHECKER	DATE
①		G.F.YANG	W.H.HSU	08/18/09
②		G.F.YANG	W.H.HSU	10/23/09
③				

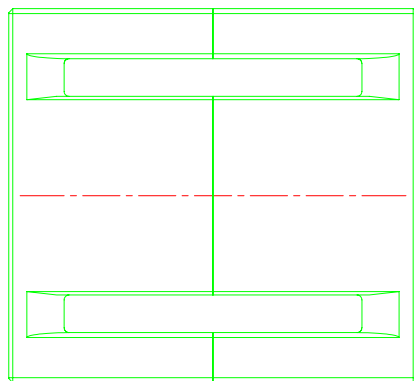
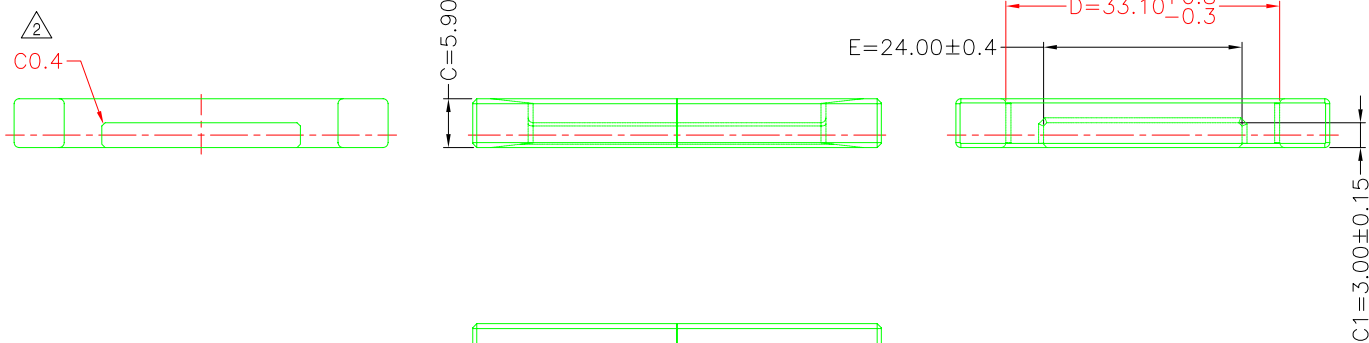
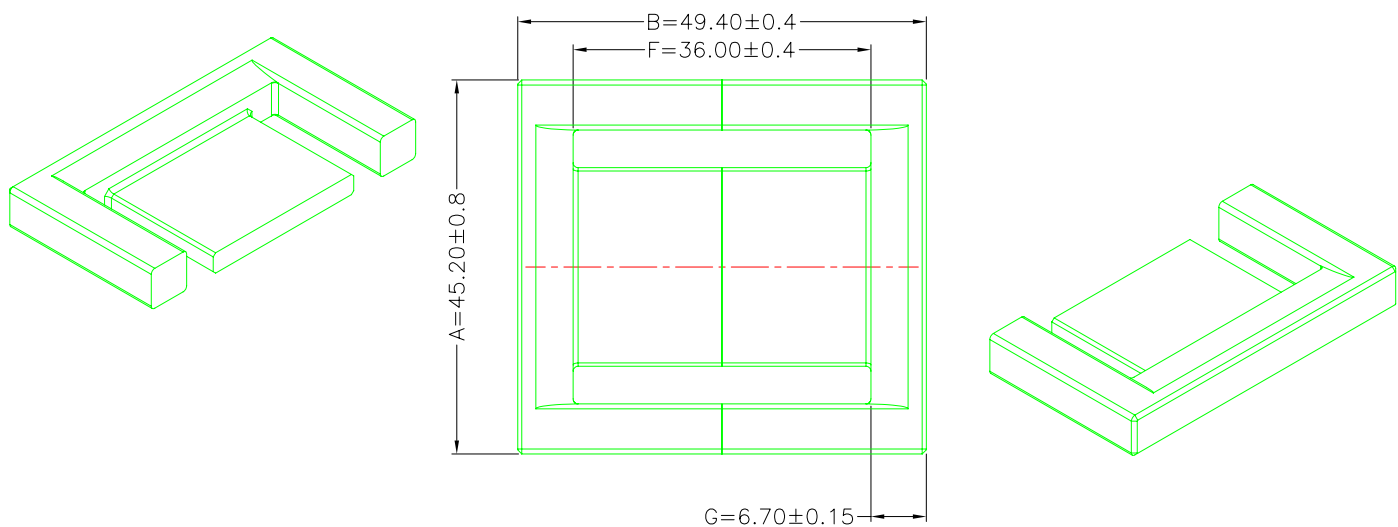

$A1(\text{Limbs})=70.77\text{mm}^2$   
 $A2(\text{back wall})=79.06\text{mm}^2$   
 $A3(\text{center post})=71.45\text{mm}^2$   
 $Ae=73\text{mm}^2$   
 $Le=106\text{mm}$   
 $C1=1.45\text{mm}^{-1}$   
 $Ve=7738\text{mm}^3$

DWG NO.	EFD45 /49.4 CORE				
PART NO.	MATERIAL (BOBBIN)	MATERIAL (TERMINAL)	TERMINAL (PLATING)	PIN ALLOCATION	NOTE
EFD45 /49.4	JPP-44A				
EFD45 /49.4	JPP-95				

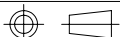

Finish:

UNIT : m/m

SCALE 1:1

REV 2

**A-CORE**

A-CORE JIANGMEN ELECTRONICS CO.,LTD  
江門安磁電子有限公司

ELECTRICAL CO. Tel : 86-750-3867791 Fax : 86-750-3867787

e-mail : sales@acore-ferrite.com

**TBI**

TRANSFORMER BOBBIN  
INDUSTRIAL CO.,LTD.

Tel : 86-769-88789999 Fax : 86-769-88789989

http://tbi-tw.com e-mail : tb6688@ms46.hinet.net

REVISIONS

REV	SYM	DRAFTER	CHECKER	DATE
△2		YAN.TANG	G.F.YANG	10/22/10
△3		G.F.YANG	W.H.HSU	12/28/10
△4		H.X.DUAN	W.H.HSU	03/23/11

TOP

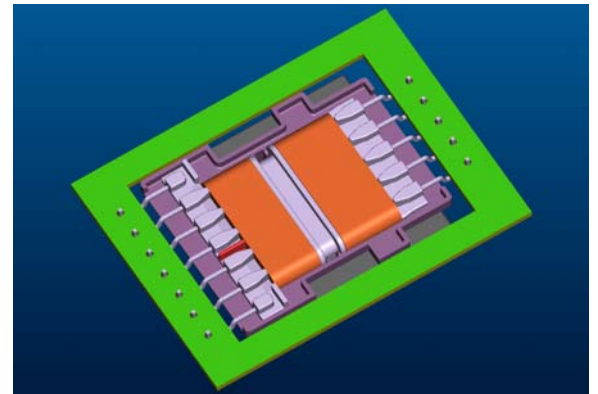
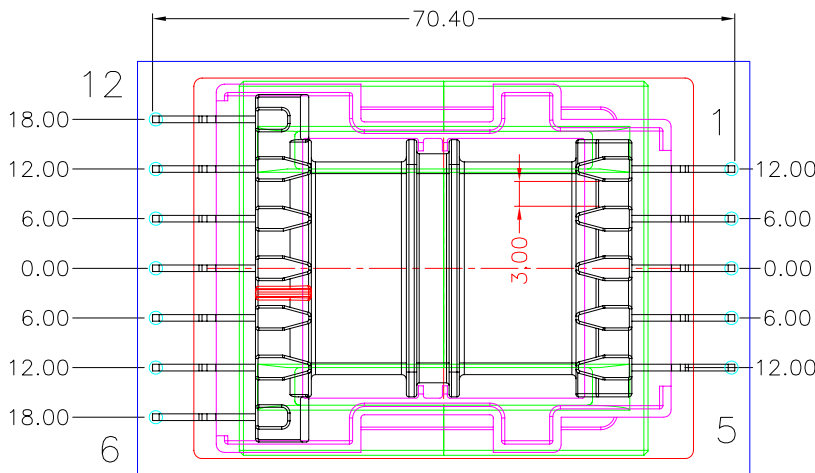
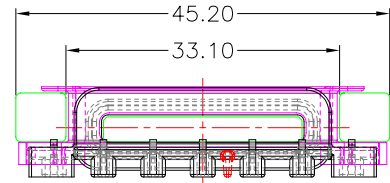
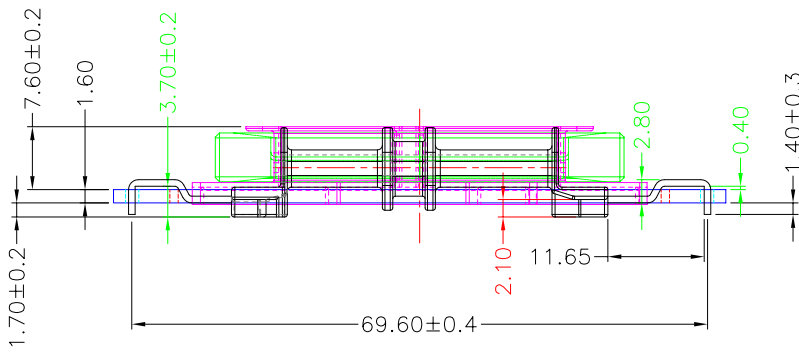
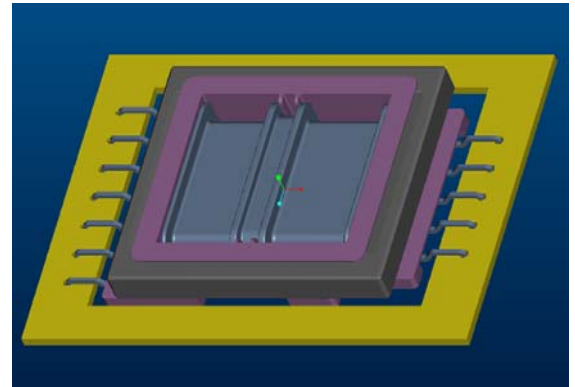
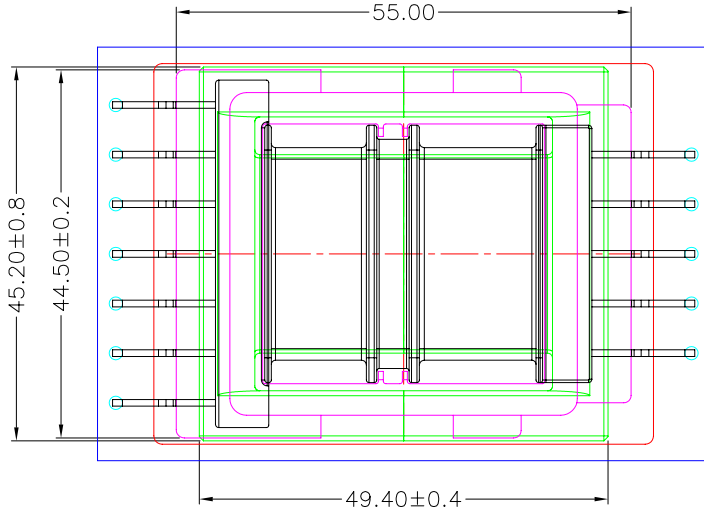

BOTTOM

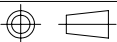
ITEM	PART NO.	MATERIAL	DWG NO.	Core Set Parameters	
CORE	EFD45-49.4	JPP-44A		$A_e=73\text{mm}^2$ $L_e=106\text{mm}$ $C_1=1.45\text{mm}^{-1}$ $V_e=7738\text{mm}^3$	
CORE	EFD45-49.4	JPP-95			
BOBBIN	TBI-207-08221.11XX		EFD45-49.4-12P-THT-2B-11		
CASE	TBI-207-08241.91C		EFD45-49.4-CASE-B4-91		
				UNIT : m/m	SCALE 1:1

REV 4