





**A-CORE**

A-CORE JIANGMEN ELECTRONICS CO.,LTD  
 江门安磁电子有限公司

**TBI**

TRANSFORMER BOBBIN  
 INDUSTRIAL CO.,LTD.

ELECTRICAL CO. Tel : 86-750-3867791 Fax : 86-750-3867787

Tel : 86-769-88789999 Fax : 86-769-88789989

e-mail : sales@acore-ferrite.com

http:// tbi-tw.com e-mail : tb6688@ms46.hinet.net

REVISIONS

REV	SYM	DRAFTER	CHECKER	DATE
△1		X.H.GU	G.F.YANG	07/28/10
△2		YAN.TANG	G.F.YANG	08/25/10
△3		X.H.GU	G.F.YANG	09/16/10

TOP

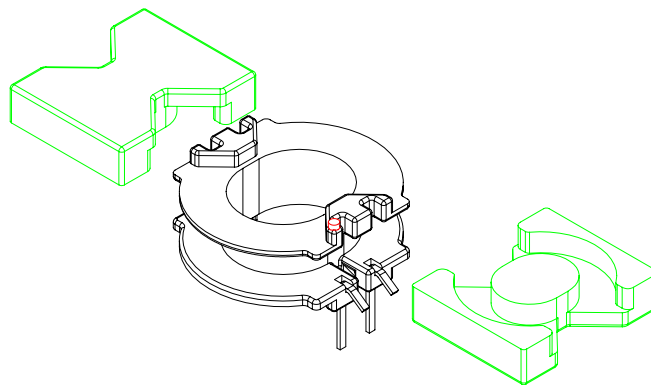
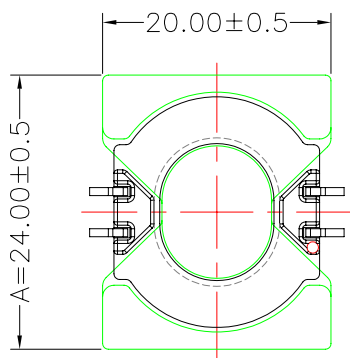

TOP

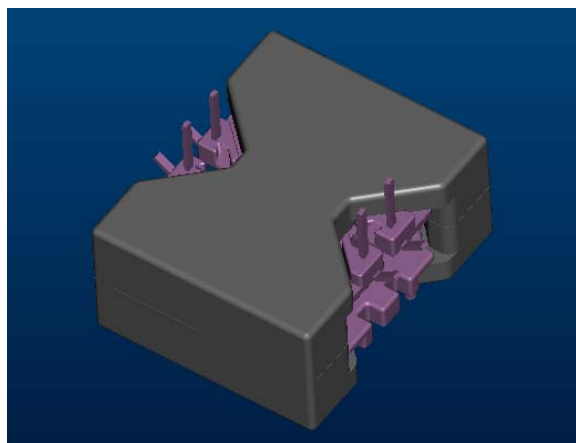
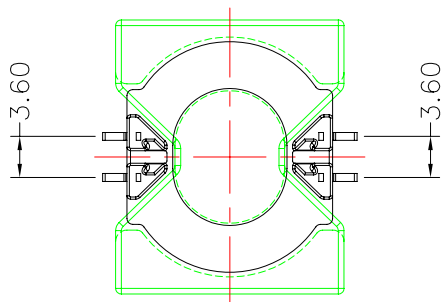
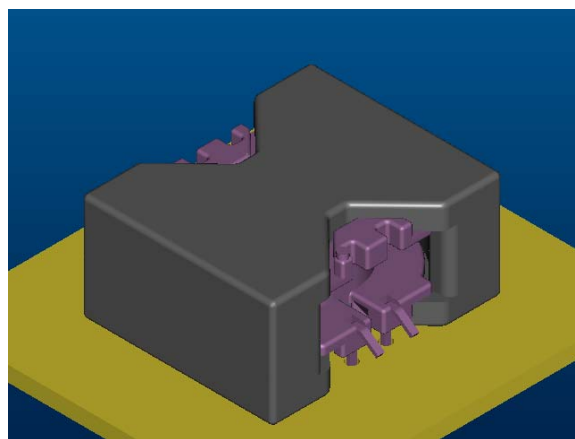
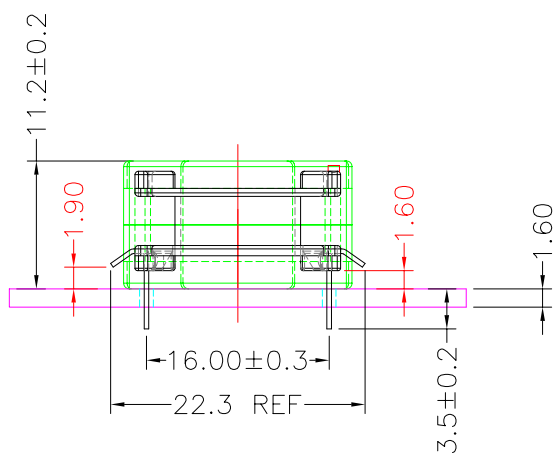

BOTTOM

BOTTOM

ITEM	PART NO.	MATERIAL	DWG NO.	Core Set Parameters
CORE	ATQ24/11.2	JPP-44A		$A_e=99.9\text{mm}^2$ $L_e=32.9\text{mm}$ $C_1=0.330\text{mm}^{-1}$ $V_e=3286.71\text{mm}^3$
CORE	ATQ24/11.2	JPP-95		
BOBBIN	TBI-238-01301.11XX		ATQ24-11.2-4P-THL-C0-11	

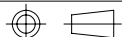

UNIT : m/m

SCALE 1 : 1

REV 3