

A-CORE

A-CORE JIANGMEN ELECTRONICS CO.,LTD
江門安磁電子有限公司

TBI

TRANSFORMER BOBBIN
INDUSTRIAL CO.,LTD.

ELECTRICAL CO. Tel : 86-750-3867791 Fax : 86-750-3867787

Tel : 86-769-88789999 Fax : 86-769-88789989

e-mail : sales@acore-ferrite.com

http:// tbi-tw.com e-mail : tb6688@ms46.hinet.net

REVISIONS

REV	SYM	DRAFTER	CHECKER	DATE
△4		YAN.TANG	G.F.YANG	09/18/09
△5		YAN.TANG	G.F.YANG	10/22/09
△6		YAN.TANG	G.F.YANG	11/20/09

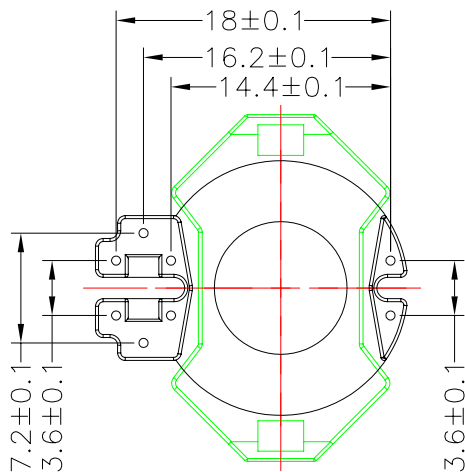
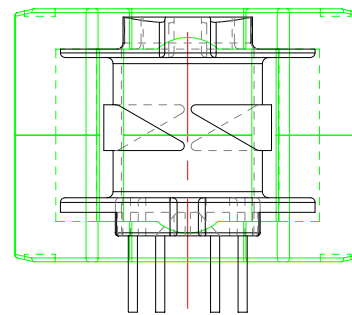
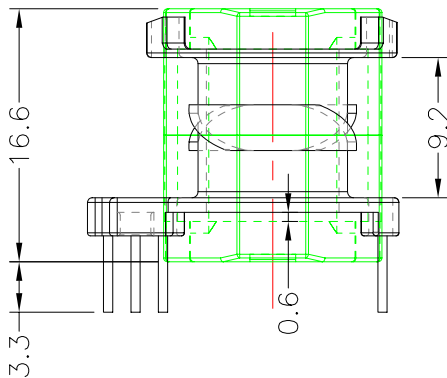
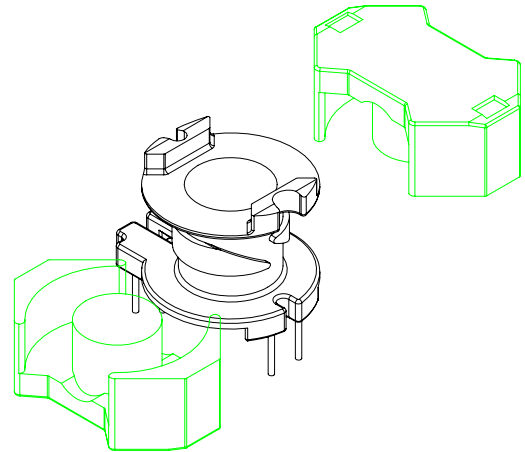
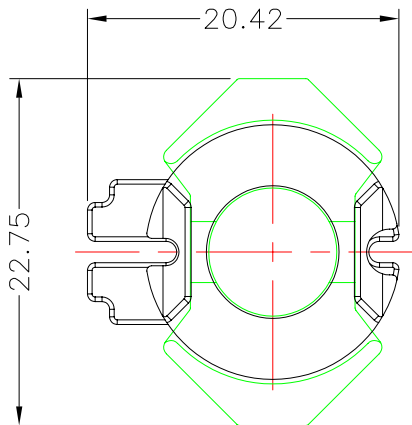

ITEM	PART NO.	MATERIAL	DWG NO.	Core Set Parameters
CORE	RM8/16.6	JPP-44A		$A_e=64.0\text{mm}^2$ $L_e=38.0\text{mm}$ $C1=0.594\text{mm}^{-1}$ $V_e=2432\text{mm}^3$
CORE	RM8/16.6	JPP-95		
BOBBIN	TBI-208-05081.11XX		RM8-8P-TH-H-11	

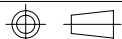

UNIT : m / m

SCALE 2:1

REV 6