





**A-CORE**

A-CORE JIANGMEN ELECTRONICS CO.,LTD  
江門安磁電子有限公司

**TBI**

TRANSFORMER BOBBIN  
INDUSTRIAL CO.,LTD.

ELECTRICAL CO. Tel : 86-750-3867791 Fax : 86-750-3867787

Tel : 86-769-88789999 Fax : 86-769-88789989

e-mail : sales@acore-ferrite.com

http:// tbi-tw.com e-mail : tb6688@ms46.hinet.net

REVISIONS

REV	SYM	DRAFTER	CHECKER	DATE
△1		X.H.GU	G.F.YANG	12/12/16
△2		X.H.GU	G.F.YANG	02/22/17
△3				

TOP

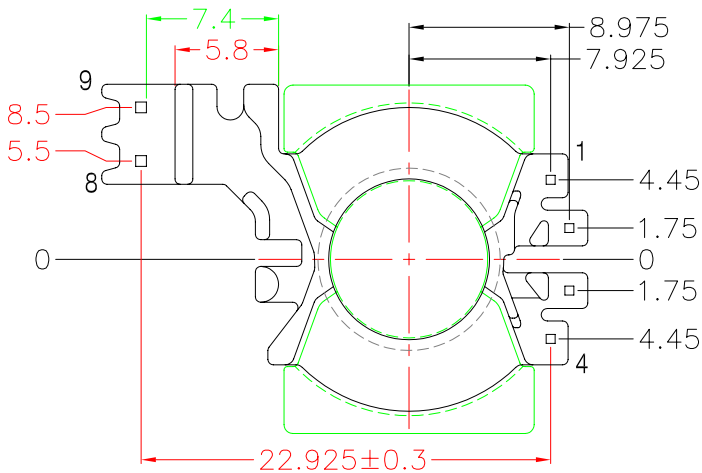
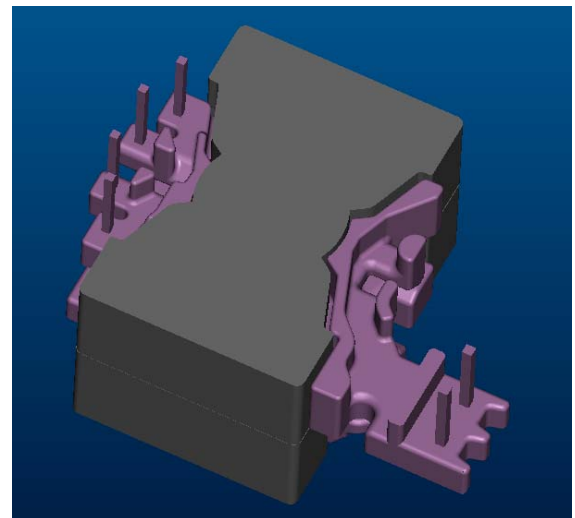
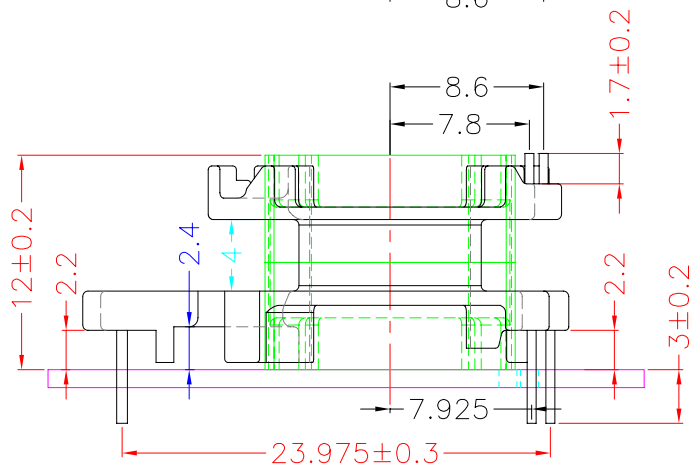
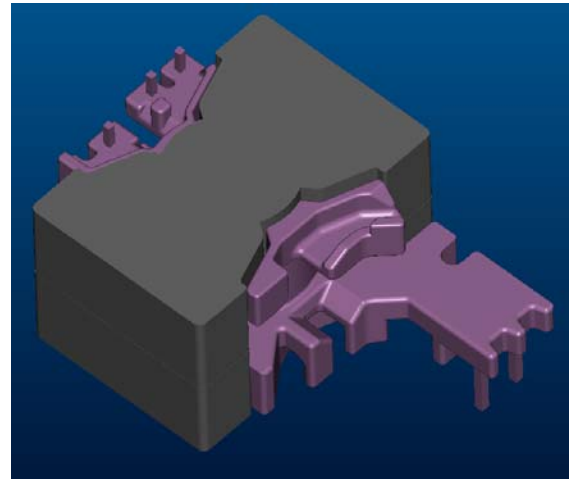
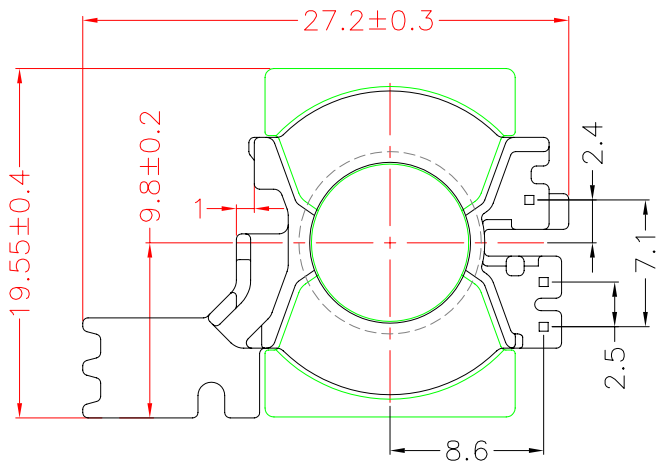

BOTTOM

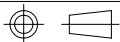
ITEM	PART NO.	MATERIAL	DWG NO.	Core Set Parameters
CORE	PQ20/12B	JPP-44A		$A_e=58.0\text{mm}^2$ $L_e=28.6\text{mm}$ $C1=0.49\text{mm}^{-1}$ $V_e=1661.8\text{mm}^3$
CORE	PQ20/12B	JPP-95		
BOBBIN	TBI-216-01051.11XX		PQ20-12B-9P-TH-E-11	
				UNIT : m/m
				SCALE 1 : 1
				REV 2