

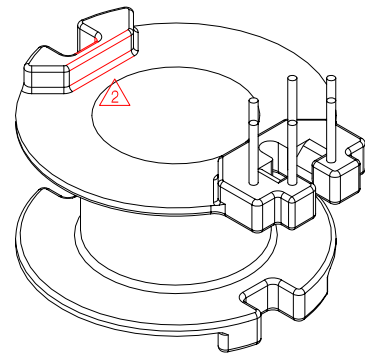

**TRANSFORMER BOBBIN
INDUSTRIAL CO.,LTD.**

Tel : 86-769-88789999 Fax : 86-769-88789989
http:// tbi-tw.com e-mail : tb6688@ms46.hinet.net

REVISIONS				
REV	SYM	DRAFTER	CHECKER	DATE
①		X.H.GU	G.F.YANG	01/25/10
②		H.X.DUAN	G.F.YANG	08/05/11
③				

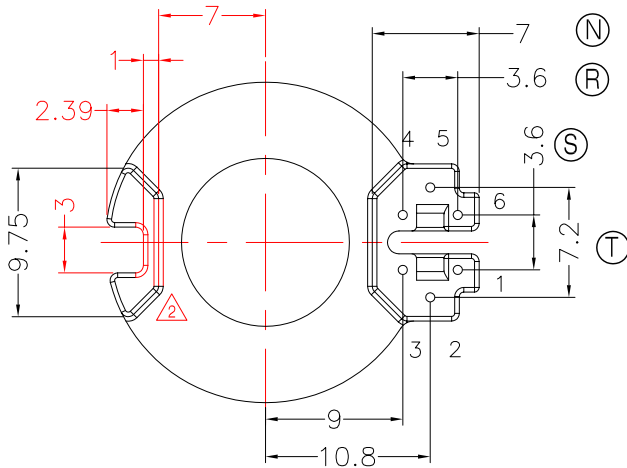
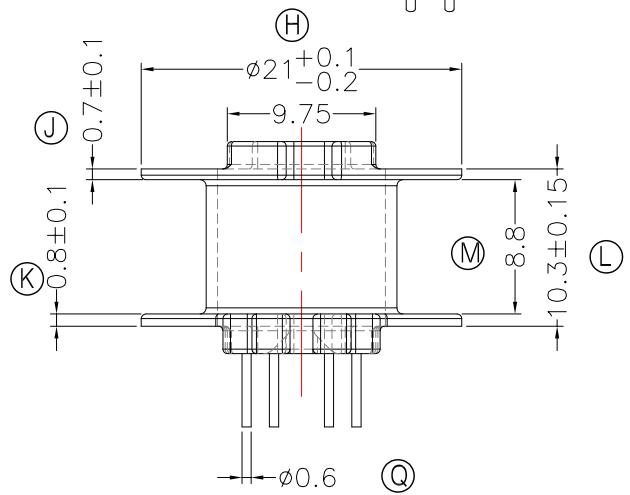
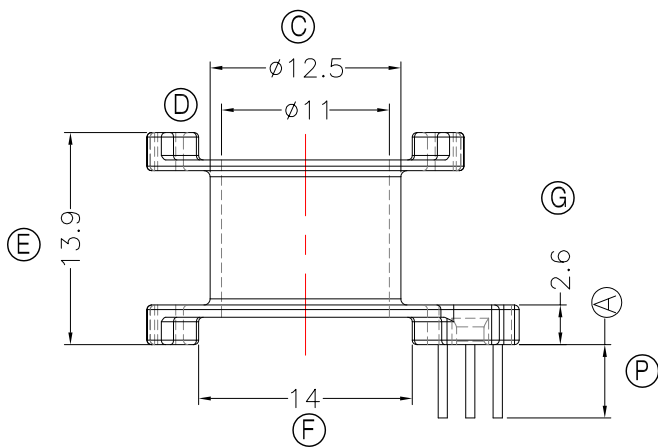
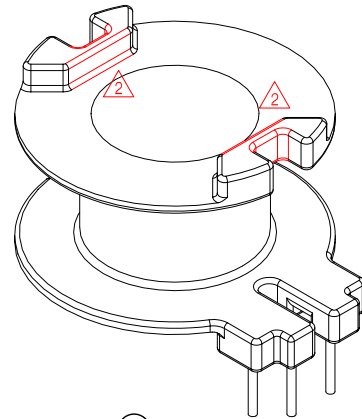
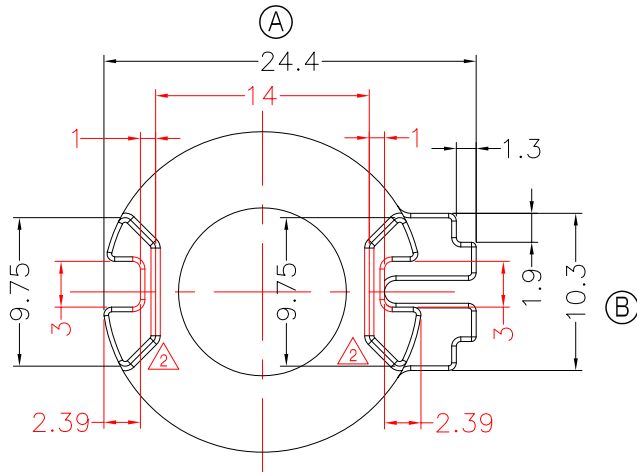

注: 1.CORE TYPE :RM10/16.9
2.焊錫前拉力:1.0KG MIN,焊錫後拉力:1.5KG MIN

DWG NO.	RM10-6P-TH-A9-11				
PART NO.	MATERIAL (BOBBIN)	MATERIAL (TERMINAL)	TERMINAL (PLATING)	PIN ALLOCATION	NOTE
TBI-208-04191.1106	PM-9630	CP WIRE	Sn	ALL PIN ①=4.8±0.2	
TBI-208-04191.1116	PM-9630	CP WIRE	Sn	CUT PIN #5 ①=4.8±0.2	H.C
TBI-208-04191.1126	PM-9630	CP WIRE	Sn	CUT PIN #2,5 ①=4.8±0.2	
TBI-208-04191.1136	PM-9630	CP WIRE	Sn	ALL PIN ①=4.0±0.2	
TBI-208-04191.1146	PM-9630	CP WIRE	Sn	ALL PIN ①=5.5±0.2	
TBI-208-04191.1156	PM-9630	CP WIRE	Sn	CUT PIN#3 ①=5.5±0.2	
	TOLERANCE:0<L<=4:±0.1 4<L<=16:±0.2 16<L<=63:±0.3			UNIT : m / m	SCALE 1 : 1

Finish: 1. PB wire Immersion Sn on terminal : Thickness:Sn plating,100,5 μm (200 μ inches) min,Base nickel 0.625 μm (25 μ inches) min.
2. CP wire Immersion Sn on terminal : Thickness:Sn plating,100,5 μm (200 μ inches) min.
3. Coplanarity deviation: 0.10 mm (0.004 inches) max.

REV 2

A-CORE

A-CORE JIANGMEN ELECTRONICS CO.,LTD
 江門安磁電子有限公司

TBI

TRANSFORMER BOBBIN
 INDUSTRIAL CO.,LTD.

ELECTRICAL CO. Tel : 86-750-3867791 Fax : 86-750-3867787

Tel : 86-769-88789999 Fax : 86-769-88789989

e-mail : sales@acore-ferrite.com

http:// tbi-tw.com e-mail : tb6688@ms46.hinet.net

REVISIONS

REV	SYM	DRAFTER	CHECKER	DATE
△1		X.H.GU	G.F.YANG	01/25/10
△2		H.X.DUAN	G.F.YANG	08/05/11
△3				

TOP

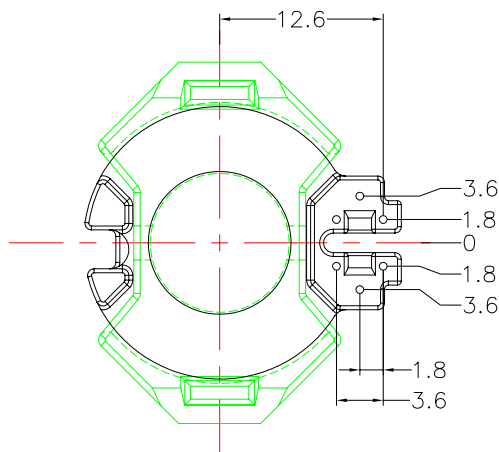
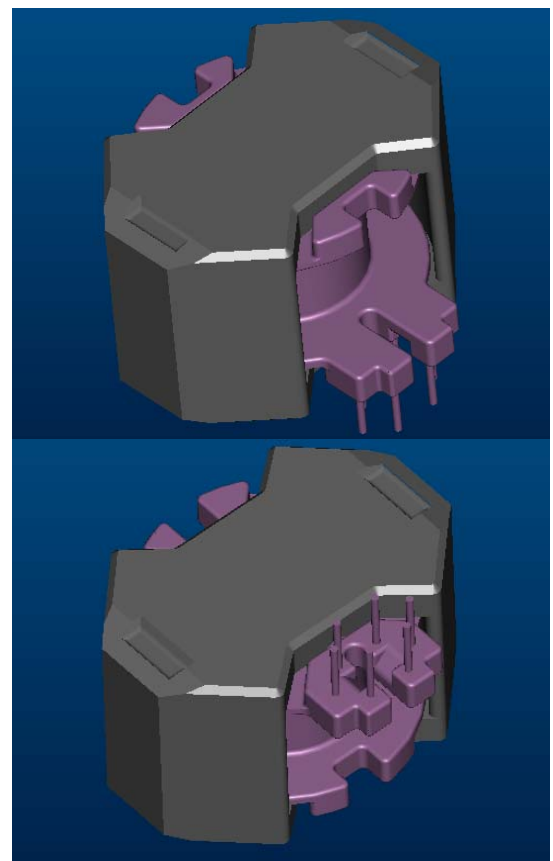
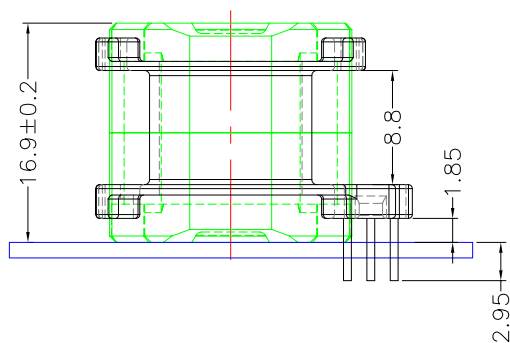
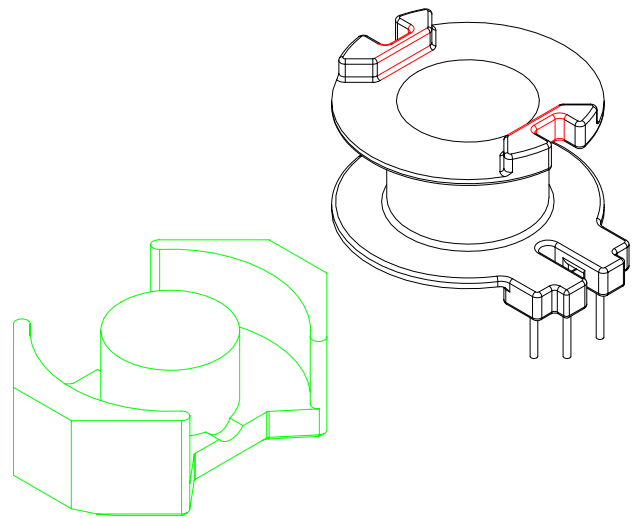
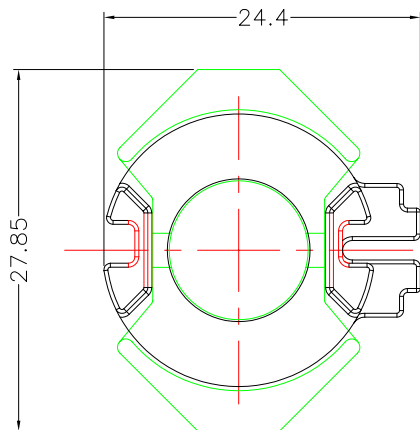

BOTTOM

ITEM	PART NO.	MATERIAL	DWG NO.	Core Set Parameters
CORE	RM10/16.9	JPP-44A		$A_e=98.00\text{mm}^2$ $L_e=40.90\text{mm}$ $C_1=0.42\text{mm}^{-1}$ $V_e=4008.20\text{mm}^3$
CORE	RM10/16.9	JPP-95		
BOBBIN	TBI-208-04191.11XX		RM10-6P-TH-A9-11	

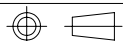

UNIT : m / m

SCALE 1 : 1

REV 2